



Operating Instructions
Sensors (WT and TE)

Resistance thermometers and thermocouples

Imprint

Manufacturer	RÖSSEL-Messtechnik GmbH
Address	Seidnitzer Weg 9 01237 Dresden Germany
Phone	+49 351 312 25-0
Fax	+49 351 312 25-25
Email	info@roessel-messtechnik.de
Internet	www.roessel-messtechnik.de

Table of contents

1	Safety	5
1.1	Intended use	5
1.2	System-specific hazards and residual risks.....	5
1.3	Operator's responsibility	6
1.4	Personnel requirements	6
1.5	Warnings	7
1.5.1	Layout of warnings.....	7
1.5.2	Meaning of the signal words and symbols.....	7
2	Layout and function	8
2.1	General description	8
2.2	Scope of delivery.....	8
2.3	Nameplate.....	9
2.4	Technical data.....	9
3	Transport, packaging and storage.....	10
3.1	Transport	10
3.2	Packaging and storage.....	10
4	Starting up and operation.....	12
4.1	Mechanical installation	12
4.1.1	Multi-point thermometers	12
4.1.2	Cable sensors.....	12
4.1.3	Cylindrical thread or permanently joined flanges	12
4.1.4	Tapered thread	12
4.1.5	Electrical thermometer with ceramic thermowell.....	13
4.2	Electrical installation.....	13
4.3	Electrical connection.....	13
4.3.1	Resistance thermometer (colour code to EN 60751)	14
4.3.2	Thermocouples (colour code to EN 60584).....	17
4.4	Preferred diameter.....	22
4.5	Tightening torques	22
4.5.1	Tightening torques between cable gland and connecting head.....	22
4.5.2	Connection between cable and cable gland	22
4.5.3	Tightening torques between connecting head and neck pipe	23
4.5.4	Tightening torques between process connection and thermowell.....	23
4.5.5	Tightening torque for compression fittings.....	23
4.6	Heat dissipation via the thermometer from the process surface	23
4.6.1	Increasing the distance of connection components from hot surfaces	24
4.7	Increasing the distance of connection components from hot surfaces.....	24
5	Correcting faults	25
6	Maintenance, cleaning and calibration	26
6.1	Maintenance.....	26
6.2	Cleaning.....	26
6.3	Calibration and recalibration.....	26

7	Dismantling, return and disposal.....	27
7.1	Dismantling.....	27
7.2	Return.....	27
7.3	Disposal.....	28

1 Safety

1.1 Intended use

The resistance thermometers and thermocouples described in this document are suitable for temperature measurement in industrial applications. Depending on their design, these devices can be installed directly in the process or in a thermowell. Any model of thermowell can be selected. The recommendation of a suitable thermowell must take into account the customer's specific process data (temperature, pressure, density and flow velocity). Repairs and structural changes are not permitted and lead to voiding of the warranty and the respective approval.

Shortening metallically sheathed cables is prohibited; the device loses its guarantee and function. Shortening extensions sheathed in plastic or glass fibre is allowed.

Structural changes after delivery of the devices are not the responsibility of the manufacturer. The device is solely designed and built for the intended use described here and may only be used in this way. The technical specifications in these operating instructions must be met. No claims of any kind whatsoever will be accepted if they result from installation and use that are not intended.

1.2 System-specific hazards and residual risks

The device itself does not cause any hazards. During the individual stages in the life of the device, hazards and residual risks exist, which can be avoided by noting and following the safety instructions and warnings in this document.

Physical injuries, property and environmental damage caused by dangerous measured materials

Contact with dangerous measured materials (e.g. oxygen, acetylene, flammable or toxic materials), harmful measured materials (e.g. corrosive, toxic, carcinogenic, radioactive), and refrigeration systems and compressors, pose a risk of physical injuries, property and environmental damage. In fault conditions, aggressive media with extreme temperature and high pressure or vacuum can be applied at the device. Work materials contaminated with residual substances can also cause hazards.

- When using, cleaning and dismantling the device in contact with dangerous or harmful measured materials, in addition to the general rules, also refer to and follow the relevant regulations and safety data sheets for the respective material.
- Suitable protective equipment must be worn if necessary.
- Dispose of work materials such as cleaning liquids or cloths properly.

Physical injuries, property and environmental damage caused by improper actions in the event of faults

- If faults cannot be corrected with the help of the actions listed in this document, shut down the device immediately.
- Make sure that a signal is no longer applied and protect against accidental starting.
- Contact Rössel-Messtechnik GmbH immediately. Refer to the notes in the [Return \[p. 27\]](#) section if returns are necessary.

Risk of injury from high pressure

- Only dismantle the device if the system is depressurised.

Risk of burns from hot measured materials

When removing the device, escaping, dangerous hot measured materials pose a risk.

- Allow the system to cool sufficiently before removing. Rule of thumb: systems should be left to cool for at least 24 hours.
- Use a handheld thermometer to check the surface temperature.

1.3 Operator's responsibility

The operator is responsible for selecting the resistance thermometer or thermocouple and thermowell as well as for selecting the material to ensure safe function in the system or machine. Offers made by Rössel-Messtechnik GmbH are merely recommendations based on our experience with similar applications.

The safety instructions in this document and the safety, accident prevention and environmental safety regulations applicable to the area of use of the devices must be complied with by the operator and the persons assigned by them. The operator is responsible for keeping the nameplate legible.

1.4 Personnel requirements

Qualification The tasks described in this document must only be carried out by electrically skilled personnel or by persons competent and assigned to do so by virtue of their respective qualifications. Inadequately qualified personnel cannot assess the risks when handling the device correctly and expose themselves and others to the risk of injuries. It is prohibited for inadequately qualified personnel to be in the work area / danger zone.

Electrically skilled personnel Electrically skilled personnel have the technical training, knowledge and experience as well as knowledge of the specific national regulations, applicable standards and guidelines/directives to be able to identify and avoid potential hazards independently. The electrically skilled personnel have been specially trained for the working environment in which they are employed and are familiar with the relevant standards and provisions. Electrically skilled personnel must fulfil the provisions of the applicable legal regulations on accident prevention.

Work on electrical installations or components may only be carried out by electrically skilled personnel.

Operating personnel The personnel trained by the operator has the education, knowledge and experience to enable them to carry out the work described and to identify potential hazards independently.

Specific operating conditions require further appropriate knowledge, e.g. about aggressive media

1.5 Warnings

1.5.1 Layout of warnings

All warnings in this document are structured as follows:

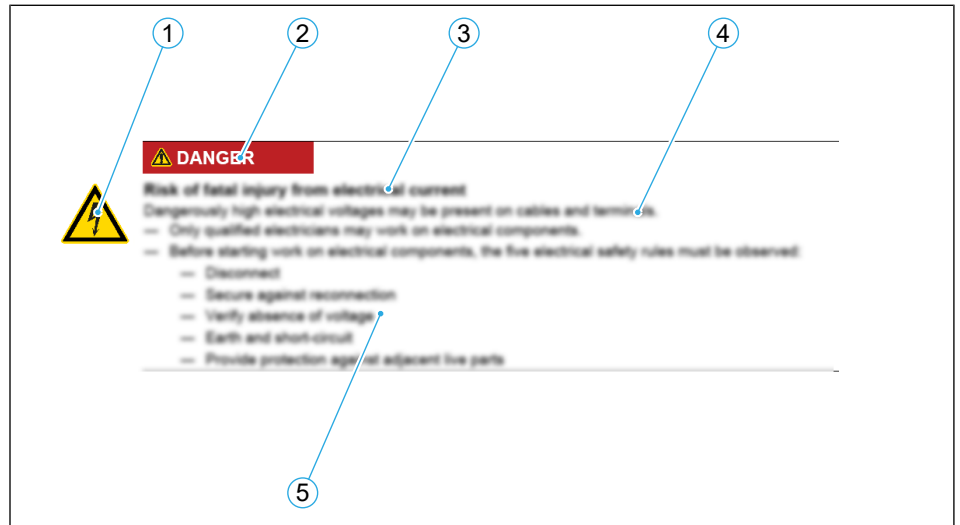

Ill. 1: Layout of warnings

1	Hazard symbol	2	Signal word
3	Type and source of danger	4	Possible consequences if disregarded
5	Procedure to avoid hazards		

1.5.2 Meaning of the signal words and symbols

The following signal words are used in this document:

Signal word	Meaning, consequences if not prevented
WARNING	Warns of a potential hazardous situation, which could result in death or serious injury.
CAUTION	Warns of a potential hazardous situation, which could result in minor or moderate injury.
ATTENTION	Warns of a hazardous situation, which can result in material damage or environmental damage.

Table 1: Meaning of the signal words

The following hazard-specific symbols are used in this document:



Symbol	Designation
	General warning
	Hot surface

Table 2: Meaning of the hazard-specific symbols

2 Layout and function

2.1 General description

Resistance thermometers and thermocouples are used for temperature measurement in industrial applications. This document describes standard design devices. Special designs are required for installation and applications in potentially explosive atmospheres and are not described here.

The temperature sensors are solely designed and built for the intended use described here and may only be used in this way.

Measurement point insulated

The resistance thermometer device type and thermocouple type consist of a welded tube (fitting), a mineral insulated sheathed cable or are made up of ceramic-insulated thermo wires within which the temperature sensor is located. This is embedded in a ceramic powder, a temperature-resistant potting compound, cement compound or a heat-conductive paste. The standard devices are electrically insulated from the outer sheath.

Thermocouples, uninsulated (grounded)

For particular applications, for example, surface temperature measurements, the thermocouples are directly contacted with the thermowell or sheath material, or the measuring points are welded onto the bottom of thermocouples.

Electrical connection

The thermocouples and resistance thermometers are connected on the customer's premises to a housing, a connector or free connection cables.

In the housing version there are terminals or transmitters. Optionally, separate digital displays can be installed in the housing.

2.2 Scope of delivery

Information on the scope of delivery can be found in the delivery item description on the delivery note.

2.3 Nameplate

The following figures show examples of nameplates and their most important components.

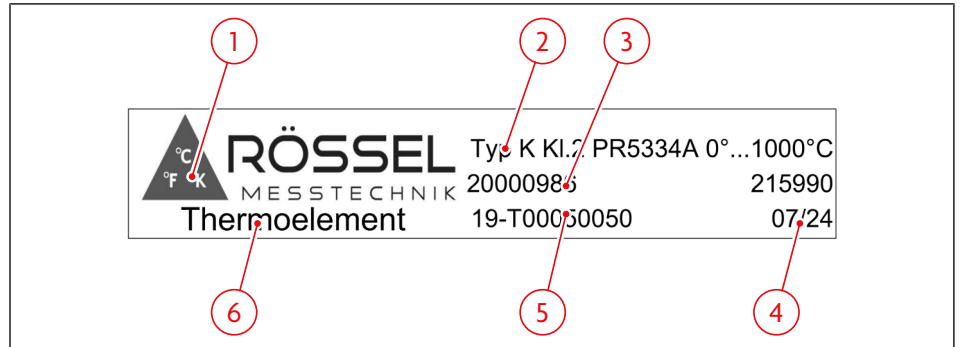

Ill. 2: Nameplate for thermocouples

1	Manufacturer	2	Details of the design (model, accuracy class...)
3	Item number	4	Period of manufacture
5	Serial number	6	Sensor type

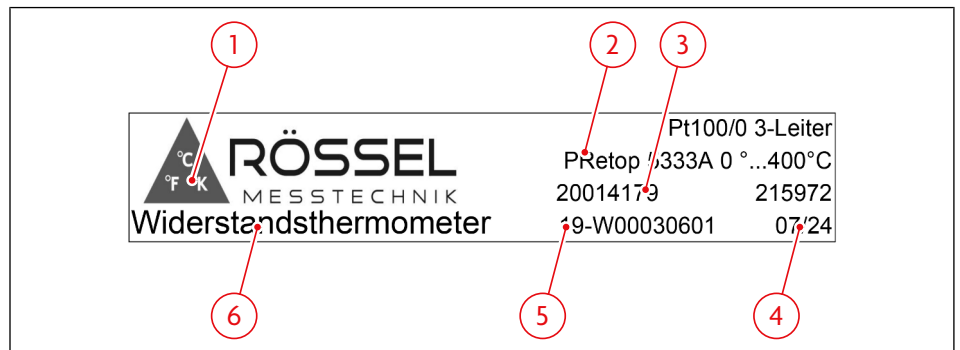

Ill. 3: Nameplate for resistance thermometers

1	Manufacturer	2	Details of the design (model, accuracy class...)
3	Item number	4	Year of manufacture
5	Serial number	6	Sensor type

2.4 Technical data

The technical data depend on the type of device. They are listed in detail on the data sheet enclosed with the device.

3 Transport, packaging and storage

3.1 Transport



WARNING

Injuries caused by large weight

Devices with a weight of more than 35 kg can cause serious injuries during transport, e.g. crushing or harm from overload/strain.

- Devices weighing more than 35 kg must always be moved by at least two persons.
- Use suitable resources.

ATTENTION

Damage caused by improper transport

Improper transport can cause substantial damage to property. The devices are breakable, precision electronic instruments.

- Work carefully when unloading the packages on delivery and during in-house transport and note the symbols on the packaging.
- Do not throw the packages.
- Refer to the notes in the ► *Packaging and storage [p. 10]* section for in-house transport.

ATTENTION

Damage caused by condensation

If the device is transported from a cold environment into a warm one, condensation can form and disrupt the function of the device.

- Before renewed startup, wait until the device temperature has adjusted to the room temperature.

1. Examine the packaging for damage before opening it. Report obvious damage immediately and refuse to accept the goods.
2. After unpacking the device, check it for possible transport damage. Report damage immediately.
3. Do not install possibly damaged devices. Have them checked by the manufacturer instead.

3.2 Packaging and storage

Allowable ambient conditions in the storage location

Storage temperature: $-20 \dots +60 \text{ }^{\circ}\text{C}$

Devices with installed transmitter: see operating instructions for the relevant transmitter.

Procedure

1. Do not remove the device from the packaging until directly before its installation in the system.
2. Avoid the following effects:
 - Direct sunlight or proximity to hot objects
 - Mechanical vibration, mechanical shock (installation on hard surface)
 - Soot, vapour, dust and corrosive gases
 - Potentially explosive atmosphere, combustible atmospheres
 - Contact with water, rain or high humidity
3. Store the device in its original packaging in a place that meets the ambient conditions listed above.

If the original packaging is not available, package and store the device as follows:

1. Place the device in suitable packaging with sufficient padding material.
2. In case of lengthy storage (more than 30 days), store sealed with sufficient desiccant in the packaging (materials are hygroscopic)

4 Starting up and operation

ATTENTION

Damage to the temperature sensors from noncompliance with the allowable operating temperature

Disregard of the allowable operating temperature, including when taking into account convection and thermal radiation, can cause the device to be damaged during installation.

- Do not fall below or exceed the operating temperature ranges specified in the data sheet.

4.1 Mechanical installation

ATTENTION

Irreparable damage to the temperature sensors caused by bending

- Do not bend rigid versions of devices.
- Keep the minimum bending radius of $5 \times D$ (D =diameter) for pliable device versions. A smaller radius causes the device to lose its warranty and function.

4.1.1 Multi-point thermometers

Multi-point thermometers are mostly equipped with a housing, in which the transducer or terminal blocks are installed. The transducer is fixed mechanically (e.g. rail system in the housing or bracket in the connecting head). In versions with cables, these lead to the terminal blocks in a remote housing.

4.1.2 Cable sensors

Cable sensors are not equipped with a housing. However, they can be connected in an additional housing, in which transducers or terminal blocks are installed.

4.1.3 Cylindrical thread or permanently joined flanges

If a thermometer connecting head, the neck pipe, the thermowell or the process connection are connected with cylindrical threads (e.g. G 1/2, M20 x 1,5 ...) or flanges (e.g. PN40/BN40, Form B1), these must be secured with seals to prevent liquids or dust from entering the thermometer.

The standard seal between the connecting head and neck pipe is a paper gasket (IT gasket) on the thermowell or a solid copper seal is used. Seals must be changed after dismantling! The operator is responsible for the suitability of the seal at the process connection.

4.1.4 Tapered thread

No other seals are used for NPT threads; PTFE tape is used to seal other tapered threads.

4.1.5 Electrical thermometer with ceramic thermowell

Ceramic thermowell materials are only conditionally resistant to temperature cycling. A temperature shock therefore easily leads to stress cracks and thus to damage of the thermowell.

Preheat thermocouples with ceramic or sapphire or composite thermowells before installation and then immerse them in the hot process slowly.

DIN 43724 recommends an insertion speed of 1 cm/min for thermowells with a diameter of 24/26 mm. In case of the smaller diameters 10/15 mm, this can be increased to 20 cm/min. Higher process temperatures basically require a longer insertion speed. In addition, ceramic thermowells must also be protected from mechanical loading. Bending forces on a horizontal installed position cause such harmful loads. A remedy is to use extended length metallic stay tubes, which provide stabilisation.

The note on the bending problem also applies to metallic thermowells, especially where installation lengths are > 500 mm. In case of process temperatures > 1,200 °C ceramic thermowells should always be installed in a vertical installed position.

Service life Due to the high thermal, chemical and mechanical loads that ceramic or sapphire thermowells are exposed to during operation, general information about the service life can only be given conditionally. This particularly applies to applications in highly loaded processes such as gasification reactors. Accordingly the process parts of the thermocouples are wearing parts, which are not covered by a guarantee.

Purge gas connection In applications with ceramic thermowells and overpressure, a purge gas connection can be provided on the thermometer.

For ceramic thermowells with purge gas connection, the basic setting is:
 Pressure of the purge gas: 0.25 ... 0.35 bar [3.6 ... 5.1 psi] above maximum process pressure
 Flow rate: approx. 10 ... 12 litre per hour with nitrogen as the purge gas.

4.2 Electrical installation

Transducers If a transducer is used, the corresponding documentation must be complied with.

Cable glands Requirements for achieving the degree of protection:

- Use the cable gland only within the stated clamping range (cable diameter matching the cable gland).
- Do not use the lower clamping range if using very soft types of cable (risk of short circuit caused by construction).
- Repeated opening/closing is possible without changing the seal.
- For cables with marked creep behaviour, retighten the glands.

4.3 Electrical connection

ATTENTION

Short-circuit risk

Damage to cables and connection points can cause malfunction of the device.

- Do not continue using damaged cables
- Fit wire end ferules on the ends of the cables of fine-wired stranded conductors.

4.3.1 Resistance thermometer (colour code to EN 60751)

4.3.1.1 Standard clamp socket, Form B (model B, WMM, WMR)

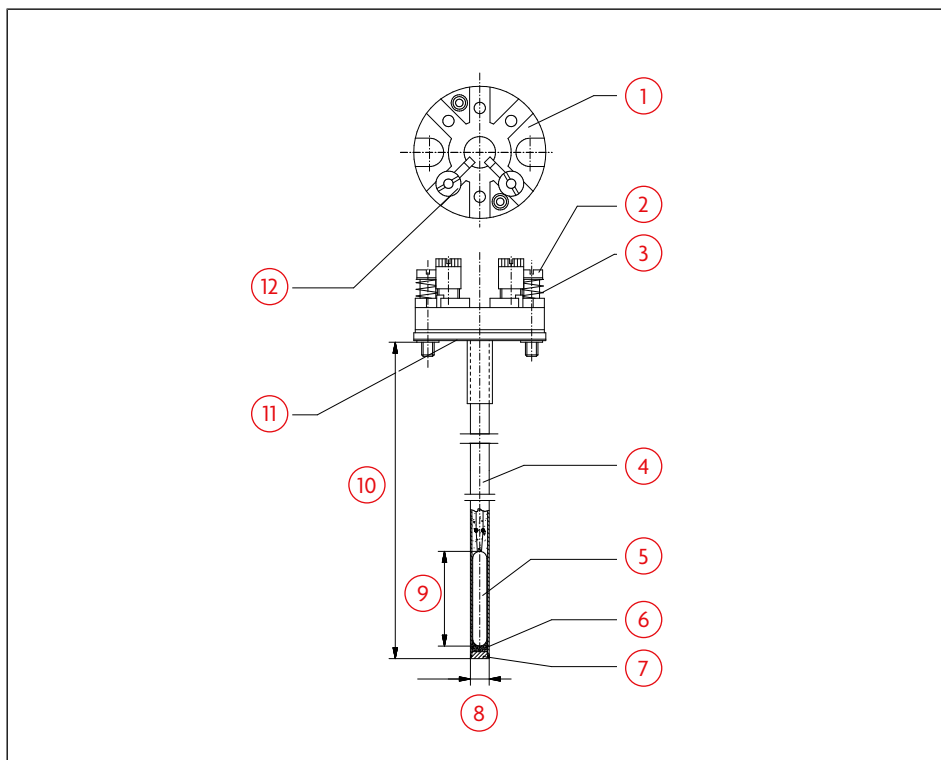

Ill. 4: Standard clamp socket, Form B (model B, WMM, WMR, example)

1	Terminal socket \varnothing 42 with 2...8 mantle terminals	2	Cheese head screw M4 \times 25
3	Compression spring \varnothing 7.5	4	Thermowell
5	Resistor — ceramic MW 1Pt / 2Pt — flat MW 1Pt / 2Pt — potted MW 1Pt / 2Pt	6	Filled with oxide
7	Floor	8	\varnothing d1
9	Active length / measuring length	10	Measuring insert length
11	Nameplate	12	Terminal

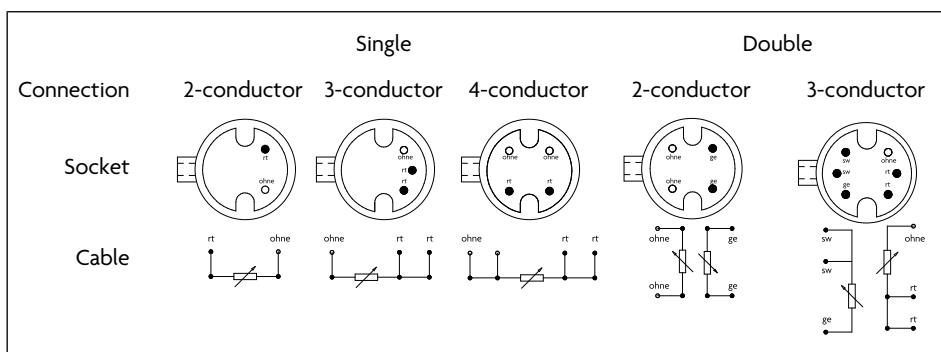

Ill. 5: Wiring options (model B, WMM, WMR)

4.3.1.2 Free cable ends (model RL or WL)

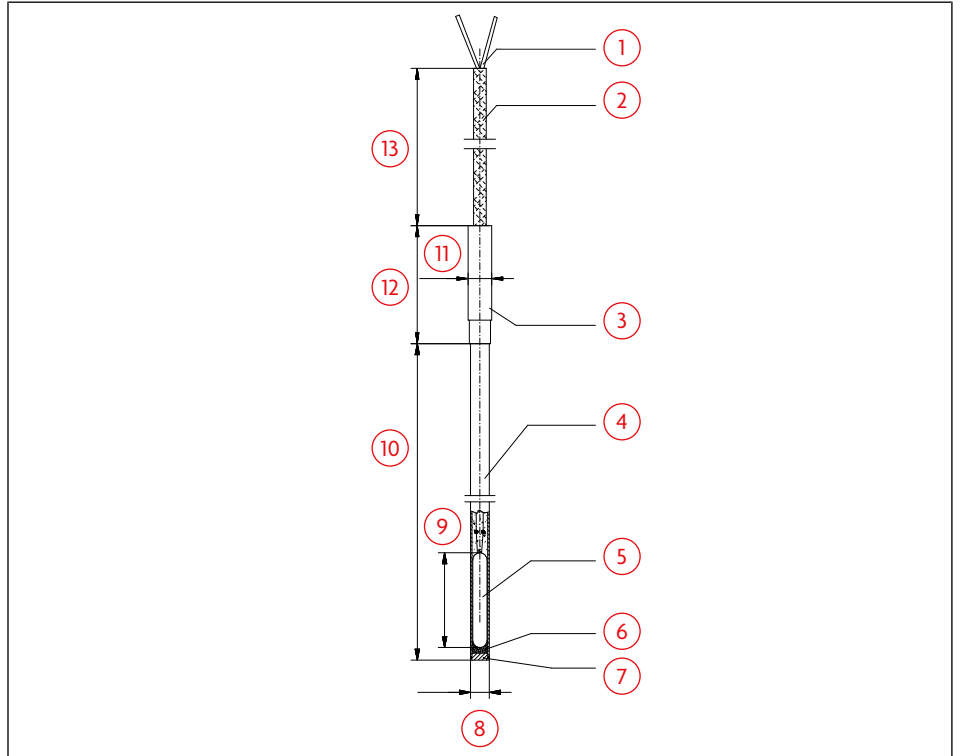

Ill. 6: Free cable ends (model RL or WL, example)

1	Free connection ends	2	Connection cable
3	Through connector (AL sleeve)	4	Thermowell
5	Resistor — ceramic MW 1Pt / 2Pt — flat MW 1Pt / 2Pt — potted MW 1Pt / 2Pt	6	Filled with oxide
7	Floor	8	Ø d1
9	Active length / measuring length	10	Nominal length
11	Ø d2	12	L3
13	L1		

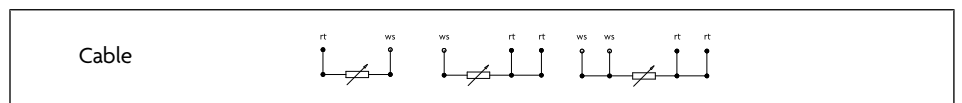

Ill. 7: Wiring options (model RL or WL)

4.3.1.3 Connector connection (model WS or WLS)

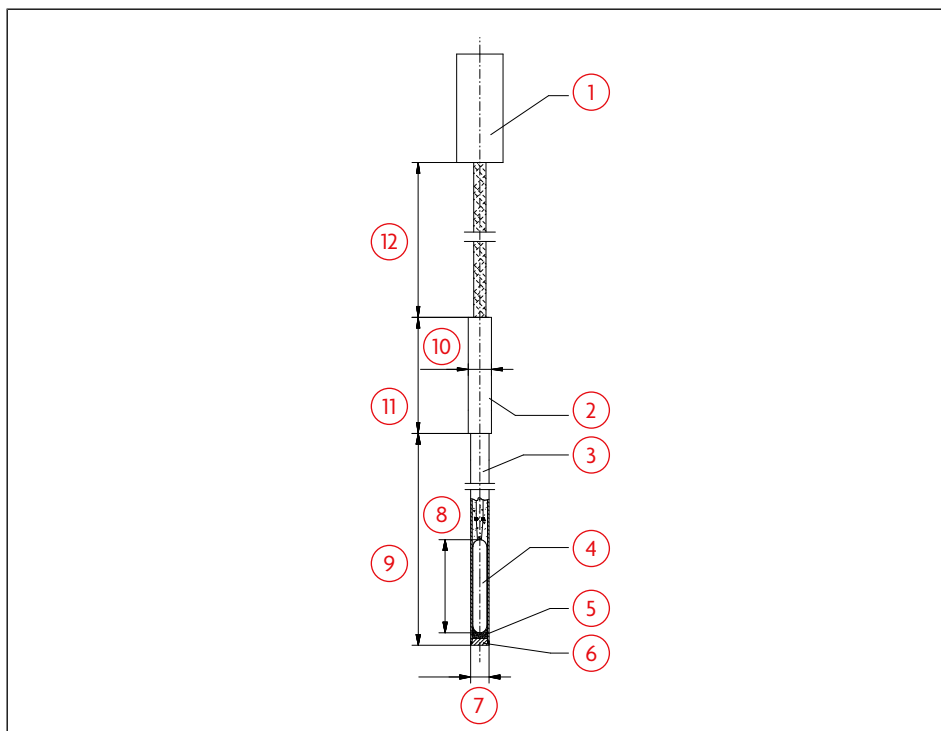

Ill. 8: Connector connection (model WS or WLS, example)

1	Connector	2	Through connector (AL sleeve)
3	Thermowell	4	Resistor — ceramic MW 1Pt / 2Pt — flat MW 1Pt / 2Pt — potted MW 1Pt / 2Pt
5	Filled with oxide	6	Floor
7	Ø d1	8	Active length / measuring length
9	Nominal length	10	Ø d2
11	L3	12	L1

The following figures show the possible versions of connector connections and their wiring.

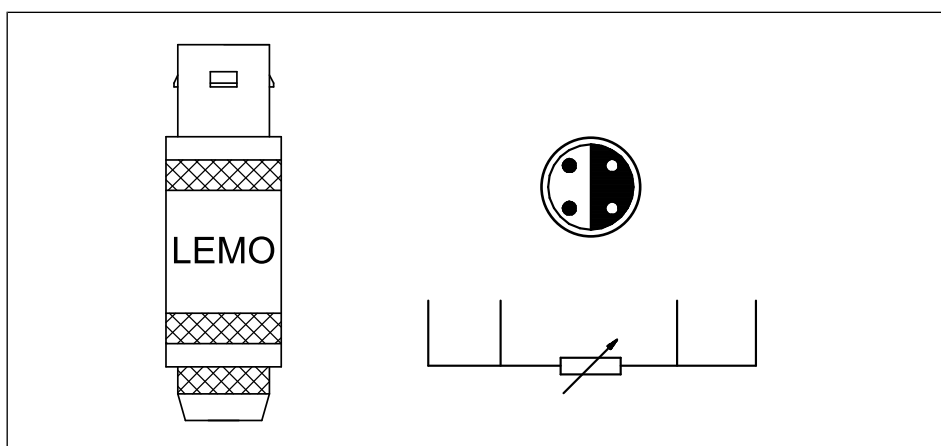

Ill. 9: 4-conductor LEMO connector RLS, size 1

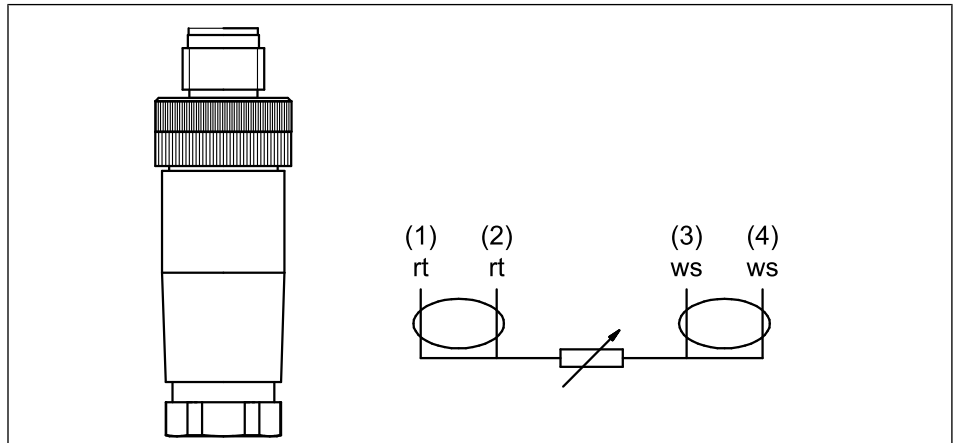

Ill. 10: 4-conductor cable connector 5-pin, M12 (shield on connector housing)

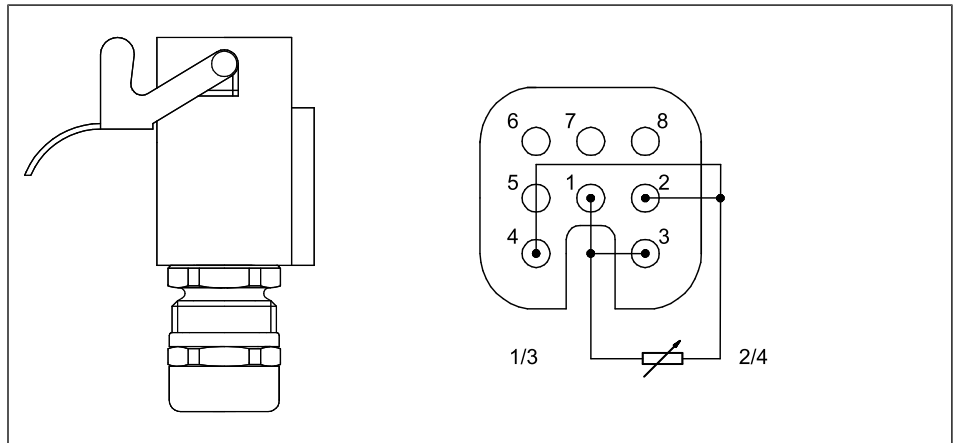

Ill. 11: 4-conductor HAN connector 8U with cap

4.3.2 Thermocouples (colour code to EN 60584)

Sensor type	Standard	Positive pole	Negative pole
K	IEC 60584-3	Green	White
J	IEC 60584-3	Black	White
E	IEC 60584-3	Violet	White
N	IEC 60584-3	Pink	White
S	IEC 60584-3	Orange	White
C	IEC 60584-3	Red	White

4.3.2.1 Standard clamp socket, Form B (model B, TMM, TMR)

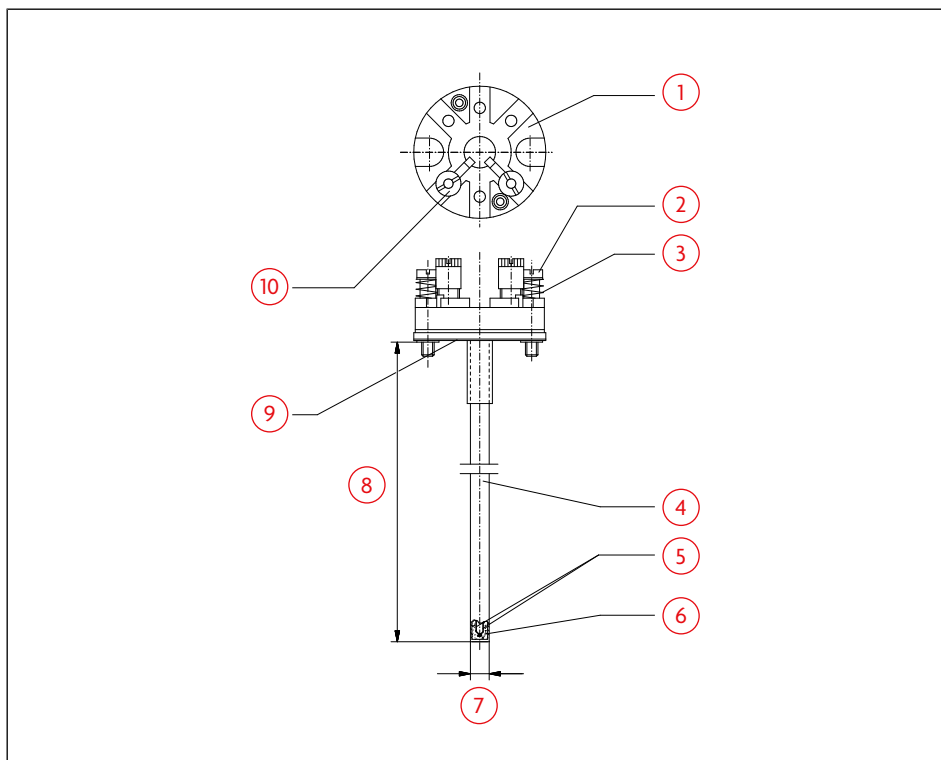

Ill. 12: Standard clamp socket, Form B (model B, TMM, TMR, example)

1	Terminal socket Ø 42 with 2...8 mantle terminals	2	Cheese head screw M4 × 25
3	Compression spring Ø 7.5	4	Sheathed cable
5	Thermocouple pairing to EN 60584-1	6	Filled with oxide
7	Ø d1	8	Measuring insert length
9	Nameplate	10	Terminal

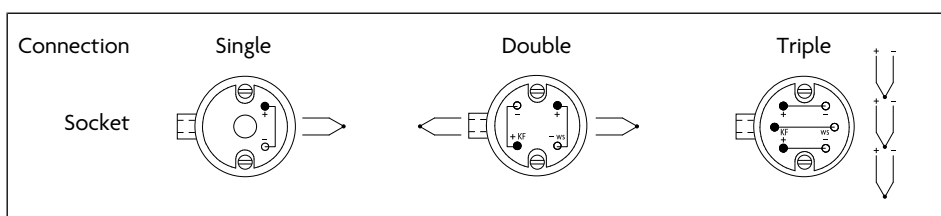

Ill. 13: Wiring options (model B, TMM, TMR)

- Single/double: only one socket with positive pole = colour code (KF) to TE standard /type and negative pole = white (ws), see drawing no. E-A-00004 / IEC 584
- Triple multi-point TE: thermocouples are arranged from the left (long) to the right (short).

4.3.2.2 Free cable ends (model AL)

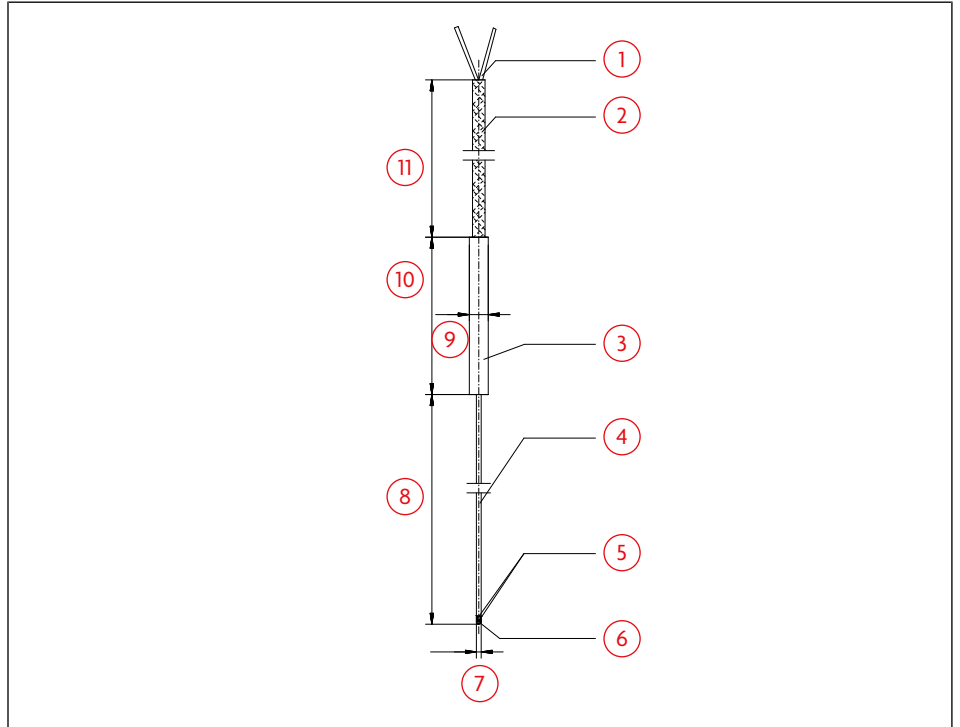

Ill. 14: Free cable ends (model AL, example)

1	Free connection ends	2	Compensating/extension cable
3	Through connector	4	Flexible sheathed cable, filled with oxide
5	Thermocouple pairing to EN 60584-1	6	Filled with oxide
7	Ø d1	8	Nominal length
9	Ø d2	10	L3
11	L1		

4.3.2.3 LEMO connector connection (model S or ALS)

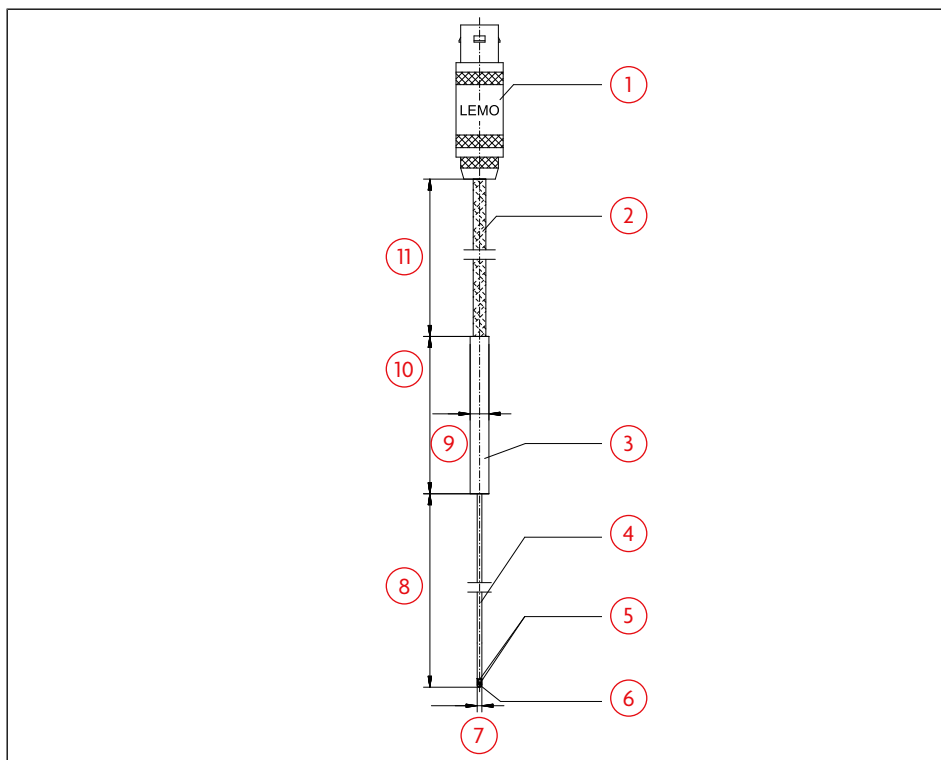

Ill. 15: LEMO connector connection (model S or ALS, example)

1	Connector, e.g. LEMO connector RLS, size 1	2	Compensating/extension cable
3	Through connector (AL sleeve)	4	Flexible sheathed cable, filled with oxide
5	Thermocouple pairing (single or double version) to EN 60584-1	6	Filled with oxide
7	$\varnothing d1$	8	Nominal length
9	$\varnothing d2$	10	L3 (50 mm, standard)
11	L1		

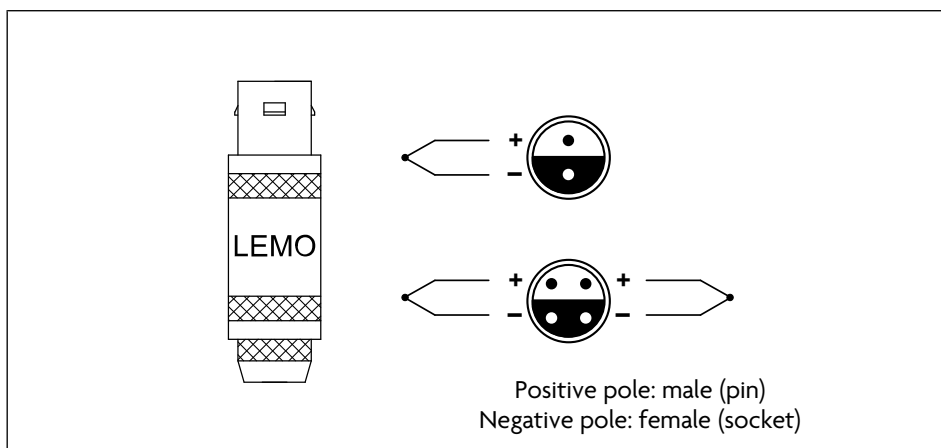

Ill. 16: Wiring of the LEMO connector

4.3.2.4 Thermocouple connector connection (model STE or ALSTE)



Ill. 17: Thermocouple connector connection (model STE or ALSTE)

1	Connector, e.g. thermal connector TS-{K}M-KER	2	Compensating/extension cable
3	Through connector (AL sleeve)	4	Flexible sheathed cable, filled with oxide
5	Thermocouple pairing (single or double version) to EN 60584-1	6	Filled with oxide
7	$\varnothing d1$	8	Nominal length
9	$\varnothing d2$	10	L3 (50 mm, standard)
11	L1		

4.4 Preferred diameter

Diameter in mm	TE_AL...	TE_STE-	TE_S	TE_Form B	TE_Form A	WT_WL..	WT_S_STE	Form RL-	WT_Form B
0.15		x	x						
0.25	x	x	x						
0.5	x	x	x						
1	x	x	x			x	x		
1.5	x	x	x			x	x		
1.6	x	x	x			x	x		
3	x	x	x			x	x	x	
3.2	x	x	x			x	x	x	
4.8	x	x	x			x	x	x	
6	x	x	x	x	x	x	x	x	x
6.4	x	x	x	x	x	x	x	x	x
8	x	x	x	x	x	x	x	x	x
9				x	x			x	x
10				x	x			x	x
11				x	x				x
15				x	x				x
18				x	x				x
22				x	x				x
24					x				
32					x				
50					x				
	pliable	pliable	pliable	rigid	rigid	pliable	pliable	rigid	rigid

Table 3: Preferred diameter depending on the model

4.5 Tightening torques

Suitable tools such as open-ended spanners or similar must always be used. Renew damaged flats.

4.5.1 Tightening torques between cable gland and connecting head

Thread	Tightening torque
M20 × 1.5	12 Nm
½" NPT	2 turns after finger tight

Table 4: Tightening torques between cable gland and connecting head

4.5.2 Connection between cable and cable gland

Screw the pressure screw tightly into the intermediate part; use suitable tools. The seal must be adapted to the cable diameter to ensure an optimum sealing effect and strain relief.

4.5.3 Tightening torques between connecting head and neck pipe

Thread	Tightening torque	
	Aluminium connecting head (Form B)	CrNi connecting head (Mat. A2)
½" NPT	2 turns after finger tight	3 turns after finger tight
G½"	32 Nm	35 Nm
M24 × 1.5	27 Nm	30 Nm

Table 5: Tightening torques between connecting head and neck pipe

4.5.4 Tightening torques between process connection and thermowell

Thread	Tightening torque
½" NPT	2 turns after finger tight
G½"	35 Nm
G1"	45 Nm
M14 × 1.5	30 Nm
M18 × 1.5	35 Nm
M20 × 1.5	40 Nm
M20 × 2	45 Nm

Table 6: Tightening torque between process connection and thermowell

4.5.5 Tightening torque for compression fittings

Compression fittings differ by their type of seals. After use (tightening the seal) the seal must be replaced if the thermometer is reused. Ensure proper fit of the seals. Only use seals of Rössel-Messtechnik GmbH.

Seal	Tightening torque	Max. pressure [bar]
Clamping ring CrNi steel	2 turns after finger tight	100
Gland CrNi steel	2 turns after finger tight	100
Clamping ring tapered PTFE	2 turns after finger tight	6

Table 7: Tightening torque for compression fittings

4.6 Heat dissipation via the thermometer from the process surface

Heat dissipation from the process, which exceeds the operating temperature of transducers, soft cables or housings, is not permitted and must be prevented by suitable thermal insulation, radiation shields or a neck pipe of suitable length.

4.6.1 Increasing the distance of connection components from hot surfaces

The neck pipe length (HRL) is defined as the distance between the bottom of the pipe retaining fitting or housing to the bottom of the hexagon of the process fitting. The temperature to be expected at the bottom of the connecting head or housing is maximum 80°C.

The conditions for installed transducers must be taken into account, the neck length must be increased if necessary.

Media temperature (max.) [°C]	Recommended neck pipe length (model B9J or C14J) [mm]	Recommended distance to adapter sleeve (model WL) [mm]
100	None	None
135	20	20
200	50	50
200 ... 450	100	100

Table 8: Recommendations for neck pipe lengths and distances

In thermometers with connection cable, the temperature at the crossover point to the connection cable is restricted. It is maximum 120 °C. By choosing dimension X, it is possible to ensure that the allowable temperature is not exceeded.

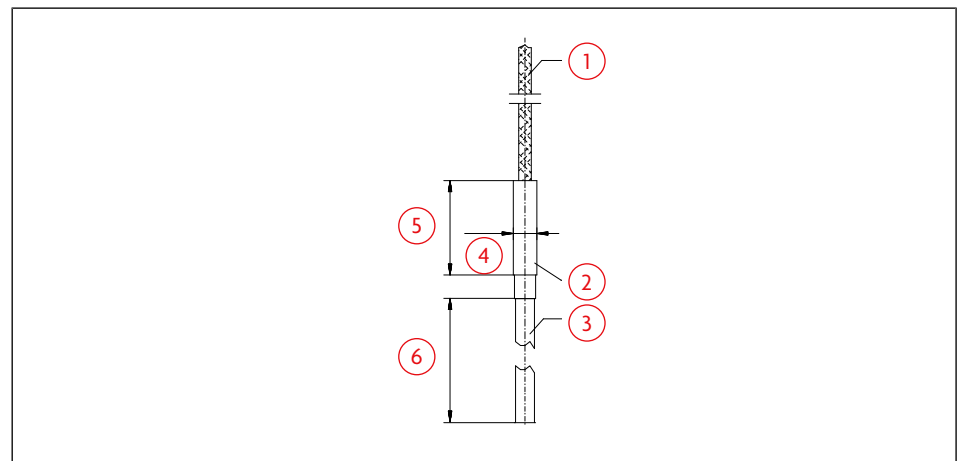

Ill. 18: Through-connector with cable and element

1	Connection cable	2	Through connector
3	Element (thermometer)	4	Ø d2 (standard 6 mm)
5	L3 (standard 50 mm)	6	X

4.7 Increasing the distance of connection components from hot surfaces

Length X is defined as the distance between the adapter sleeve (AL sleeve) on the soft cable to the heat-radiating surface.

The allowed temperature at the crossover point is maximum 120 °C.

5 Correcting faults

WARNING



Physical injuries, property and environmental damage caused by dangerous measured materials

Contact with dangerous measured materials (e.g. oxygen, acetylene, flammable or toxic materials), harmful measured materials (e.g. corrosive, toxic, carcinogenic, radioactive), and refrigeration systems and compressors, pose a risk of physical injuries, property and environmental damage. In fault conditions, aggressive media with extreme temperature and high pressure or vacuum can be applied at the device. Work materials contaminated with residual substances can also cause hazards.

- When using, cleaning and dismantling the device in contact with dangerous or harmful measured materials, in addition to the general rules, also refer to and follow the relevant regulations and safety data sheets for the respective material.
- Suitable protective equipment must be worn if necessary.
- Dispose of work materials such as cleaning liquids or cloths properly.

CAUTION



Physical injuries, property and environmental damage caused by improper actions in the event of faults

- If faults cannot be corrected with the help of the actions listed, shut down the device immediately.
- Make sure that a signal is no longer applied and protect against accidental starting.
- Contact Rössel-Messtechnik GmbH immediately. Refer to the notes in the ► *Return [p. 27]* section if returns are necessary.

Fault	Possible cause	Action
No signal/cable break	Mechanical load too high or excess temperature	Replace with a different model
Faulty measured value	Sensor drift caused by excess temperature	Replace with a different model or a different sensor type
	Sensor drift caused by chemical attack	Use more suitable thermowell material
Faulty measured value and response time too long	Installation depth too small or heat dissipation too high	Adjust model
	Deposit on the thermowell (limescale/oxide)	Remove deposits
Faulty measured value (too low)	Moisture ingress in the sensor, poor insulation value	Return, replace the temperature sensor
Faulty measured values of thermocouples	Parasitic e.m.f. or incorrect compensating or extension cable type (thermocouple)	Use correct compensating or extension cable
Measured value jumps	Cable break, loose contact, external field interference	Use anti-kink springs, thicker cable, shielded cables
Corrosion	Customer medium (fluid) has changed, incorrect thermowell material selected	Analyse medium and use a more suitable thermowell material
Signal disturbed	Interference caused by electrical fields or ground loop	Use shielded cables, use battery-operated measuring devices, use additional galvanic isolation
	Ground loop	Remove potential, use galvanically isolated batteries / splitters, use transducers
	Magnet field interference	Increase the distance

6 Maintenance, cleaning and calibration

6.1 Maintenance

This devices described in this document are maintenance-free. Repairs must be solely carried out by the manufacturer.

6.2 Cleaning

WARNING



Physical injuries, property and environmental damage caused by dangerous measured materials

Contact with dangerous measured materials (e.g. oxygen, acetylene, flammable or toxic materials), harmful measured materials (e.g. corrosive, toxic, carcinogenic, radioactive), and refrigeration systems and compressors, pose a risk of physical injuries, property and environmental damage. In fault conditions, aggressive media with extreme temperature and high pressure or vacuum can be applied at the device. Work materials contaminated with residual substances can also cause hazards.

- When using, cleaning and dismantling the device in contact with dangerous or harmful measured materials, in addition to the general rules, also refer to and follow the relevant regulations and safety data sheets for the respective material.
- Suitable protective equipment must be worn if necessary.
- Dispose of work materials such as cleaning liquids or cloths properly.

ATTENTION

Damage caused by improper cleaning

Unsuitable cleaning agents and improper work methods when cleaning can cause irreparable damage to the device.

- Only use mild, pH-neutral cleaning agents and soft, lint-free cloths or sponges to clean the surfaces gently.
- Do not use metal brushes, sharp or pointed objects or steel wool for cleaning.

1. Shut down the device to be cleaned and then dismantle it.
2. Clean the device with a damp cloth.
3. Renew all seals before reinstallation.

6.3 Calibration and recalibration

We recommend recalibrating the measuring insert at regular intervals.

Device type	Recommended interval
Class B resistance thermometer	approx. 24 months
Resistance thermometer with restricted tolerance	approx. 12 months
Thermocouples	approx. 12 months

Table 9: Recalibration cycles

This period reduces depending on the in situ conditions, the temperature cycling ratio, and reaching the maximum working temperature. The operator is responsible for estimating the recalibration cycles as part of their risk assessment.

The calibration can be carried out by the manufacturer and by qualified skilled personnel on site using calibration devices.

7 Dismantling, return and disposal

7.1 Dismantling

WARNING



Physical injuries, property and environmental damage caused by dangerous measured materials

Contact with dangerous measured materials (e.g. oxygen, acetylene, flammable or toxic materials), harmful measured materials (e.g. corrosive, toxic, carcinogenic, radioactive), and refrigeration systems and compressors, pose a risk of physical injuries, property and environmental damage. In fault conditions, aggressive media with extreme temperature and high pressure or vacuum can be applied at the device. Work materials contaminated with residual substances can also cause hazards.

- When using, cleaning and dismantling the device in contact with dangerous or harmful measured materials, in addition to the general rules, also refer to and follow the relevant regulations and safety data sheets for the respective material.
- Suitable protective equipment must be worn if necessary.
- Dispose of work materials such as cleaning liquids or cloths properly.

WARNING



Risk of injury from high pressure

- Only dismantle the device if the system is depressurised.

WARNING



Risk of burns from hot measured materials

When removing the device, escaping, dangerous hot measured materials pose a risk.

- Allow the system to cool sufficiently before removing. Rule of thumb: systems should be left to cool for at least 24 hours.
- Use a handheld thermometer to check the surface temperature.

7.2 Return

- ✓ All devices returned to Rössel-Messtechnik must be returned free from any kind of hazardous substances (acids, alkalis, solutions, etc.). Cleaning by a specialised firm must be verified.
- 1. In case of hazardous substances, enclose the safety data sheet for the relevant measured material.
- 2. Clean the device (► [Cleaning \[p. 26\]](#)).
- 3. Use the original packaging or suitable transport packaging to return the device. We will also be pleased to collect defective devices from you.
- 4. To avoid damage:
 - Place the device with the padding material in the packaging.
 - Pad uniformly on all sides of the transport packaging.
 - If possible, include a bag with desiccant in the packaging.
 - Mark the consignment ("Highly sensitive measuring device" or "Caution! Glass").

7.3 Disposal

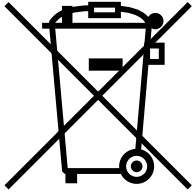

Incorrect disposal can cause hazards for the environment.

Dispose of device components and packaging materials in an environmentally friendly way according to the specific national waste treatment and disposal regulations. Do not dispose of the device with household waste. Follow the national and local safety, disposal and environmental regulations for disposal. If in doubt, ask your local municipal authority or bring in an approved specialist company.

Electronic components (transducers) can be returned to RösseL-Messtechnik GmbH where they will be properly disposed of. Extension and compensating cables are not electronic components.

Notes

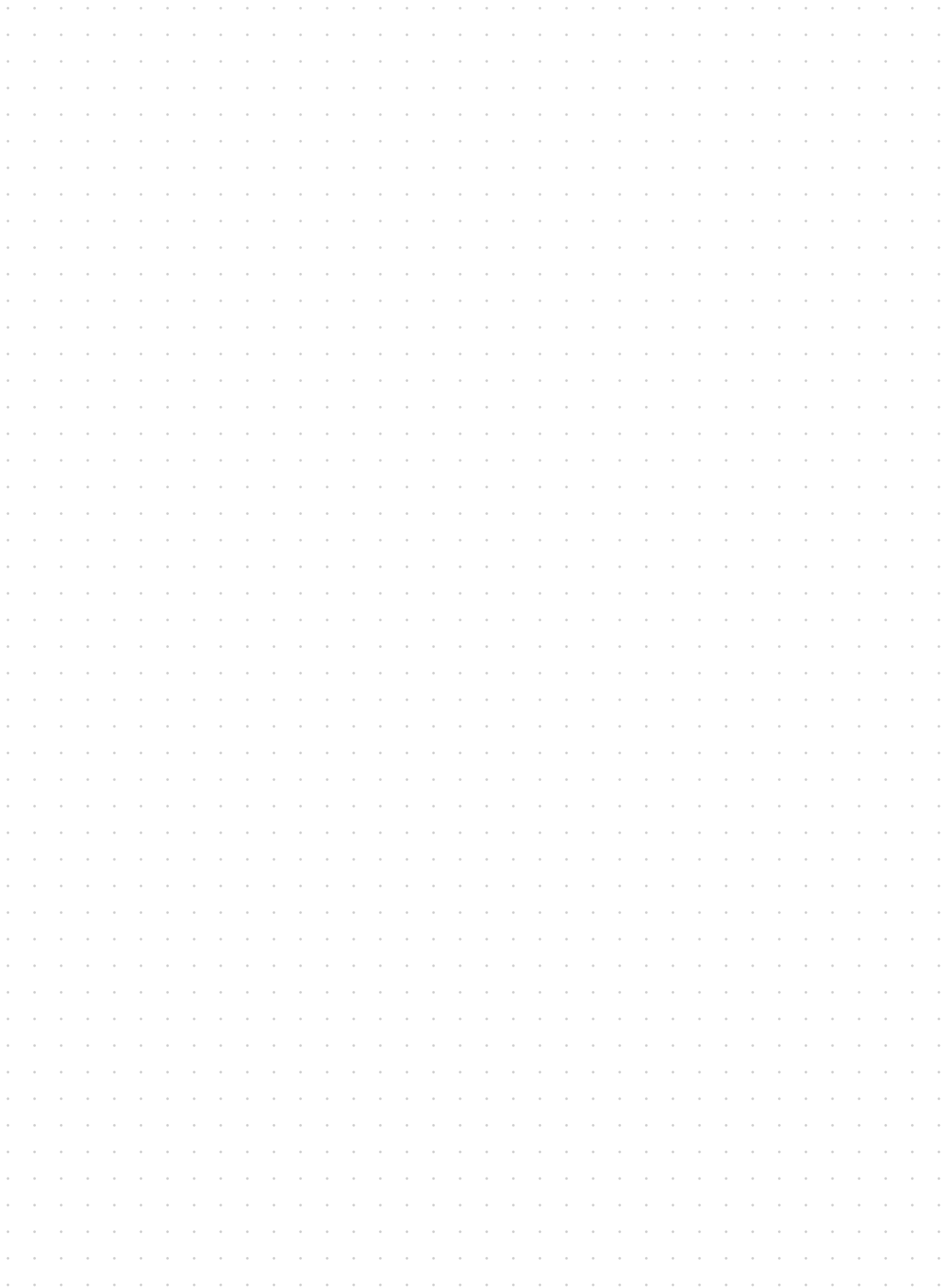



Consultation. Solution. Innovation.

V1.0
12/2025