

Consultation. Solution. Innovation.

## SHEATHED THERMOCOUPLES

DESIGNED TO MEASURE TEMPERATURES IN INDUSTRY, LABORATORIES AND RESEARCH

Sheathed thermocouples have successfully been introduced as temperature measurement technology. The standard versions are mainly used in a temperature range between  $-270\text{ °C}$  and  $+1200\text{ °C}$  and combine the advantages of high flexibility and easy handling over a wide temperature range.

We also offer high temperature thermocouples with application temperatures of up to  $2000\text{ °C}$ , with limited flexibility depending on the material. Inconel 600, a nickel-based alloy, is used as the standard sheath material. This material can be easily welded and soldered, possesses excellent strength and can withstand most environmental conditions.

The most commonly used thermocouple is composed of a nickel and nickel/chromium leg, otherwise known as type K. The thermocouple wires are embedded in a compact insulation made of high-purity  $\text{MgO}$  and encased in a metal sheath made of a nickel/chromium/iron alloy or stainless steel. The compact insulation fixes the wires securely so that no damage can occur due to strong vibrations or high bending loads. Short circuits between the wires or between the wire and the sheath are essentially ruled out as a result.

### SPECIAL ADVANTAGES:

- ✓ Mechanical stability
- ✓ Quick to respond
- ✓ Impressive bending properties
- ✓ Particularly shockproof
- ✓ Wide range of types for almost every application scenario
- ✓ Wide temperature range
- ✓ from  $-270\text{ °C}$  to over  $2000\text{ °C}$

SHEATHED THERMOCOUPLES

Sheathed thermocouples are highly versatile thanks to their special design. Compared to conventional rigid versions, smaller versions can be produced for the same use. Thanks to their bending properties, they can also be used to take reliable measurements in hard-to-reach measuring points. Thermometers 30 m in length can also be produced for routing over longer distances, e.g. through a combustion chamber ( $T > 600^{\circ}\text{C}$ ), for example. Long thermometers are used in the automotive industry, in power plants, refineries, smelting works, in shipbuilding, in the chemical industry, in combustion engines, test benches, turbines, in medicine, in boilers and furnaces, in the smelting industry, in sintering furnaces, in vacuum and high vacuum systems, etc.

The response time of a contact thermometer indicates how quickly the thermometer responds to a sudden change in temperature. These tests are carried out under standardized conditions to improve reproducibility (referred to here as measuring conditions). The time response of a temperature sensor is exponential. Initially, the sensor and the surrounding medium should be at temperature  $T_1$ . Then the temperature of the medium changes suddenly to  $T_2$ . The sensor only acknowledges this value with a time delay. The course of the measurement signal represents the transition function. Two values have been selected to represent the function:  $t_{0.5}$  and  $t_{0.9}$ . This refers to the time at which the measurement signal reaches 50 % or 90 % of the final value.

Response time of sheathed thermocouples in seconds (-5 %/+15 %)

Measurement condition	Time taken to reach value sec.	Measuring point insulated by the sheath Sheath diameter in mm						
		0.5	1.0	1.5	3.0	4.5	6.0	8.0
Water	50 %	0.06	0.15	0.21	1.2	2.5	4.0	7
0.2 m/s	90 %	0.13	0.5	0.6	2.9	5.9	9.6	17
Air	50 %	1.8	3	8	23	37	60	100
2 m/s	90 %	5.9	15	25	80	120	200	360

Sheathed thermocouples  
Measuring ranges from  $< -200^{\circ}\text{C}$  to  $> 1200^{\circ}\text{C}$

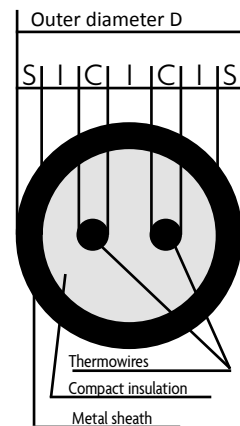
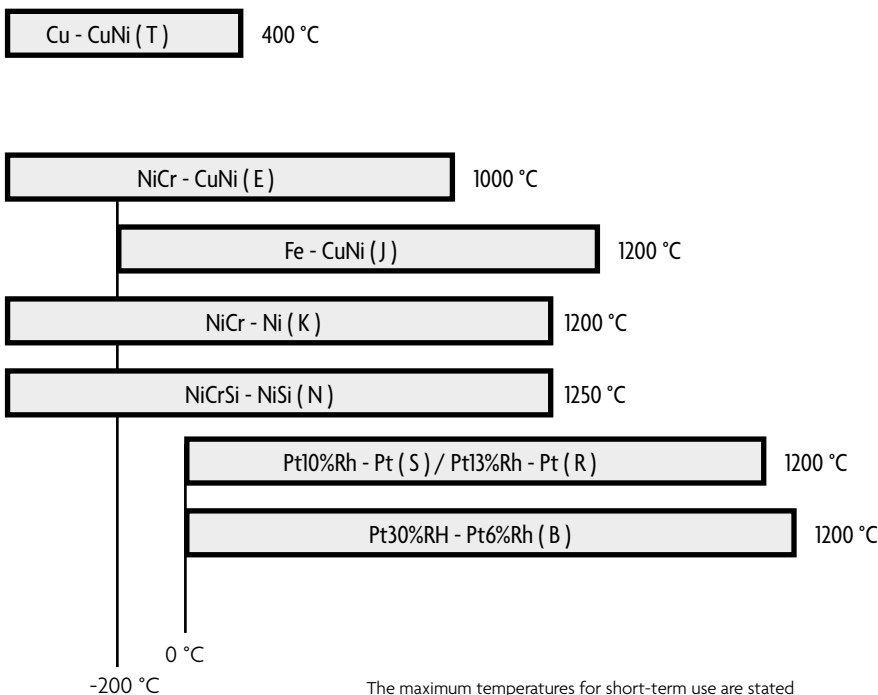

Sheathed cable cross section pursuant to DIN EN 61 515

Wall thickness S	0.10 x D
Conduction diameter C	0.15 x D
Insulation strength I	0.08 x D
Minimum dimension stated	

## COLOR CODING, BASIC VALUES AND LIMIT DEVIATIONS

### Color coding for extension or compensating cables pursuant to IEC 60 584-3

Material	Fe-CuNi	NiCr-Ni	Cu-CuNi	NiCr-CuNi	NiCrSi-NiSi	Pt10%Rh-Pt	Pt13%Rh-Pt	Pt30%Rh-Pt6%Rh
Code letter	J	K	T	E	N	S	R	B
Color	Black	Green	Brown	Purple	Pink	Orange	Orange	Gray
Positive pole	---	(Red)	(Red)	---	---	(Red)	(Red)	---
Color	White	White	White	White	White	White	White	White
Negative pole	---	(Green)	(Brown)	---	---	(White)	(White)	---
Color	Black	Green	Brown	Purple	Pink	Orange	Orange	Gray
Sheath	---	(Green)	(Brown)	---	---	(White)	(White)	---

### Basic values for thermoelectric voltages of thermocouples as per DIN EN 60 584-1

Temperature in °C	Type J in µV	Type K in µV	Type T in µV	Type E in µV	Type N in µV	Type S in µV	Type R in µV	Type B in µV	Type C in µV	Type A in µV
-200	-7890	-5891	-5603	-8825	-3990					
-100	-4633	-3554	-3379	-5237	-2407					
0	0	0	0	0	0	0	0	0	0	1
100	5269	4096	4279	6319	2774	646	647	33	1451	1337
200	10779	8138	9288	13421	5913	1441	1469	178	3090	2872
300	16327	12209	14862	21036	9341	2323	2401	431	4865	4513
400	21848	16397	20872	28946	12974	3259	3408	787	6732	6204
500	27393	20644		37005	16748	4233	4471	1242	8657	7908
600	33102	24905		45093	20613	5239	5583	1792	10609	9606
700	39132	29129		53112	24527	6275	6743	2431	12559	11284
800	45494	33275		61017	28455	7345	7950	3154	14494	12934
900	51877	37326		68787	32371	8449	9205	3957	16398	14550
1000	57953	41276		76373	36256	9587	10506	4834	18260	16128
1100	63792	45119			40087	10757	11850	5780	20071	17662
1200	69553	48838			43846	11951	13228	6786	21825	19150
1300		52410			47513	13159	14629	7848	23520	20589
1400						14373	16040	8956	25155	21976
1500						15582	17451	10099	26729	23311
1600						16777	18849	11263	28243	24593
1700						17947	20222	12433	29696	25822
1800								13591	31087	26998
1900									32413	28120
2000									33669	29186

### LIMIT DEVIATIONS FOR SELECTED THERMOCOUPLES PURSUANT TO DIN EN 60 584- 1

Limit deviation	Class 1	Class 2	Class 3
Limit deviation ± *)	0.5 °C or 0.004 * (t) °C	1.0 °C or 0.0075 * (t) °C	----
Measurement range type T	Measurement range -40 to + 350 °C	Measurement range -270 to + 400 °C	----
Limit deviation ± *)	1.5 °C or 0.004 * (t) °C	2.5 °C or 0.0075 * (t) °C	4.0 °C or 0.005 * (t) °C
Measurement range type J	Measurement range -40 to + 750 °C	Measurement range -40 to + 750 °C	Types J, K, E and N
Measurement range type K and N	Measurement range -40 to + 1000 °C	Measurement range -40 to + 1200 °C	Measurement range -200 to 40 °C
Measurement range type E	Measurement range -40 to + 800 °C	Measurement range -40 to + 900 °C	
Limit deviation ± *)	1.0 or (1+(t-1100)*0.003) °C	1.5 °C or 0.0025 * (t) °C	
Measurement range type S and R	0 to 1600 °C	Measurement range 0 to + 1600 °C	----
Measurement range type B	Not standardized	Measurement range + 600 to + 1700 °C	

The thermocouple material available as standard satisfies the limit deviations for temperatures above -40 °C according to the table above. At low temperatures, these materials do not necessarily comply with the limit deviations for class 3 (4.0 °C or 0.005 \* |t| in °C). If type E, J, K and N thermocouples that satisfy the limit deviations for class 3 as well as class 1 or 2 are required, this must be explicitly specified by the user as this generally requires the specific selection of available material.



**AL VERSION WITH PERMANENTLY CONNECTED CABLE**

With this version the connection cable is permanently connected. The transition sleeve has a diameter of 6 or 8 mm depending on the cable type. The standard length is 50 mm. The cable type (wire cross-section, insulation structure, shielding) can be varied within wide limits. A shielded cable individually and jointly insulated with FEP with a 0.25 mm<sup>2</sup> cross-section is used as standard. The maximum sleeve temperature is 150 °C. Please specify the required connector version when placing an order.



**S VERSION WITH PERMANENTLY CONNECTED COUPLER**

With the S version, the connector system is directly connected to the sheathed thermocouple. The standard version includes a type RLK size 0 coupler (up to 1.6 mm sheath diameter. Size 1 required for larger diameters). The positive pole is positioned on the pin. The contacts are made of brass and are gold-plated. The maximum coupler temperature is 150 °C. Other connector systems are available on request. Please specify the required connector version when placing an order.

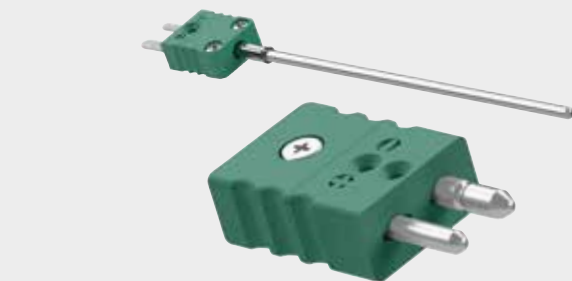

**STE VERSION WITH PERMANENTLY CONNECTED THERMOCOUPLE CONNECTOR MINI OR STANDARD**

With the STE version, the connector is directly connected to the sheathed thermocouple. The standard version is fitted with a miniature connector (TC-dia. =1.6 mm) or standard connector. The contacts are made of a thermocouple material; the outer housing is made of temperature-resistant plastic. The maximum connector temperature is 150 °C. The connector and coupler are connected with the correct poles for optimum contact reliability. Other connector systems are available on request along with matching couplers. Please specify the required version when placing an order.

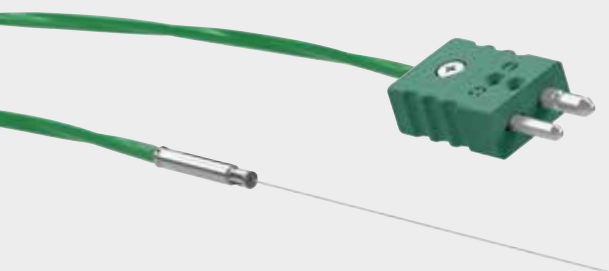

**ALSTE VERSION WITH PERMANENTLY CONNECTED CABLE AND THERMOCOUPLE CONNECTOR**

The ALSTE version is the AL version including a thermocouple connector. This version includes a mini or standard connector depending on customer specifications. The contacts are made of a thermocouple material; the outer housing is made of temperature-resistant plastic. The connector and sleeve temperature are based on the cable used and limited to a maximum of 150 °C. Other versions, e.g. with circular connectors, are also available on request.

### ALS VERSION WITH PERMANENTLY CONNECTED CABLE AND LEMO ROUND COUPLER

The ALS version is the AL version including a LEMO round coupler. This design includes a round coupler size 0 or 1 depending on customer specifications or the cable diameter. Other versions and sizes, e.g. with LEMO round couplers, are available on request.

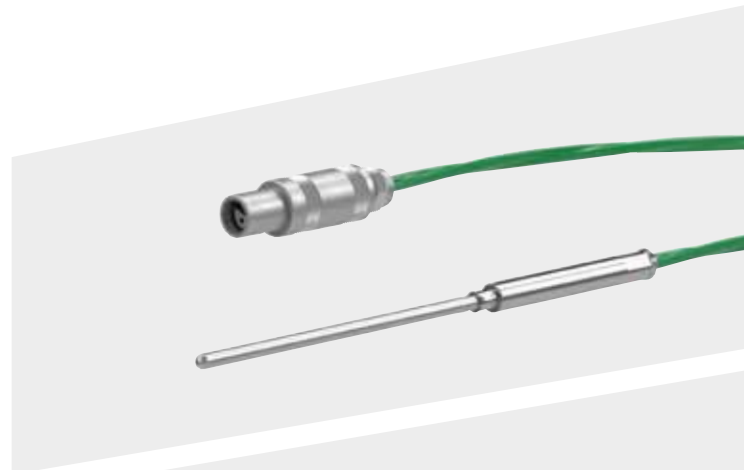

### B-KB version sheathed thermocouples with type B connection head

This version consists of a measuring insert with a connector base and sheath terminal installed in a type B connection head as standard in accordance with EN 50 446. See TMM version for information on the sheath diameter. A special pipe screw joint holds the measuring insert in place. The nominal length from the lower edge of this joint is specified. Other heads are available on request. Please specify the required version when placing an order.

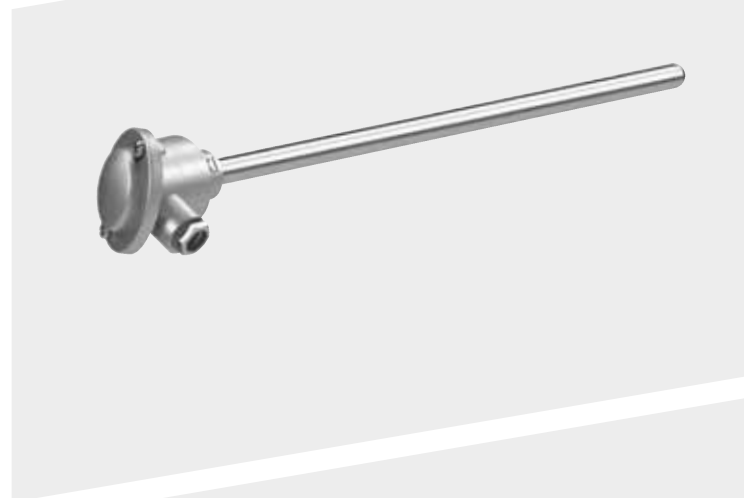

### TMM VERSION WITH SHEATH MEASURING INSERT, CONTINUOUS DIAMETER OR REINFORCED MEASURING INSERT

Measuring insert with connector base, sheath terminals and pressing device suitable for installation in type B connection heads in accordance with EN 50 446, for example. Other combinations are available on request. More details can be found in product information 076 "Measuring inserts with metal protecting tubes"

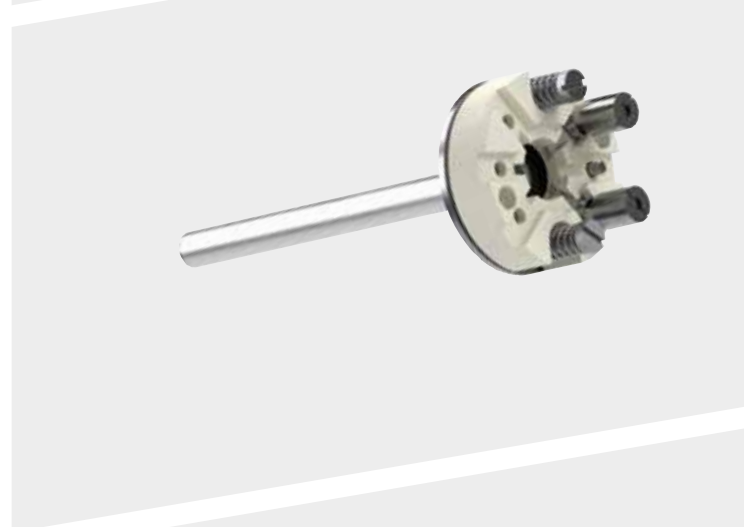

#### Versions:

- | A. Sheath diameter 3.0 mm, continuous
- | B. Sheath diameter 6.0 mm, continuous
- | C. Sheath diameter 6.0 mm, measuring tip 8 mm diameter x 50 mm length
- | D. Sheath diameter 8.0 mm, continuous

### AL-RT version sheathed thermocouple with mounting plate

The basic version of the sheathed thermocouple can be selected in accordance with the specifications on pages 4 and 5 of this product information, with the exception of the TMM version. The shape, type, design and, most importantly, the material of the mounting plate must be precisely specified. All high temperature and precious metal thermocouples as well as sheath diameters of < 1.0 mm are not available in this version. The temperature at the transition sleeve is determined by the cable used and limited to a maximum of 150 °C. Special versions are available on request. Please specify the required version when placing an order, including dimensions A and B, the thickness and material.

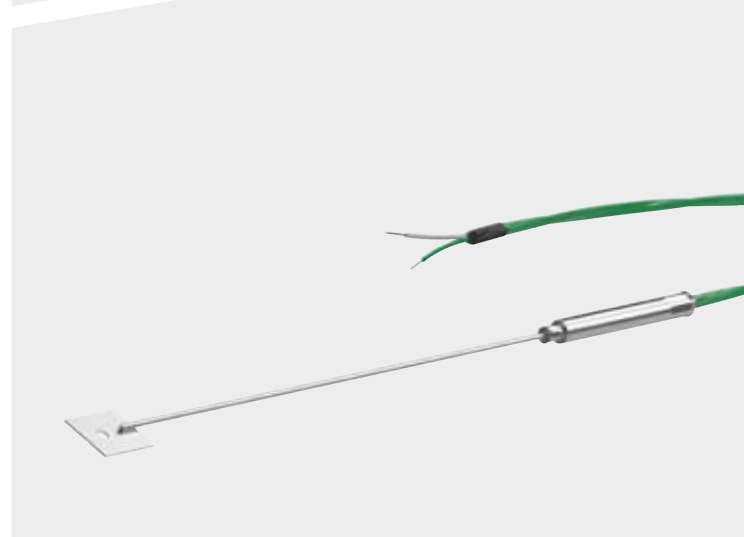

Socket assignment version TMM or B-KB

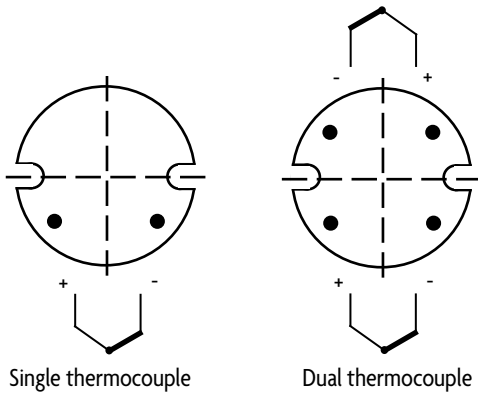

Pin assignment version S or ALS

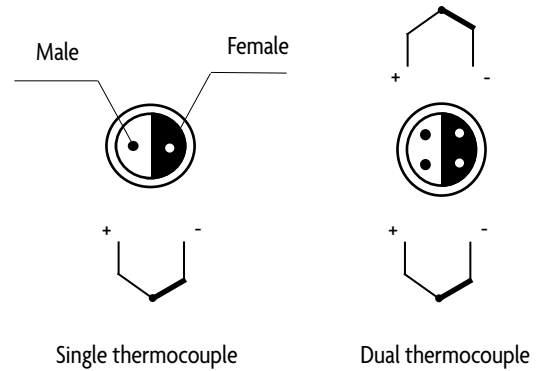

Pin assignment thermocouple - plug

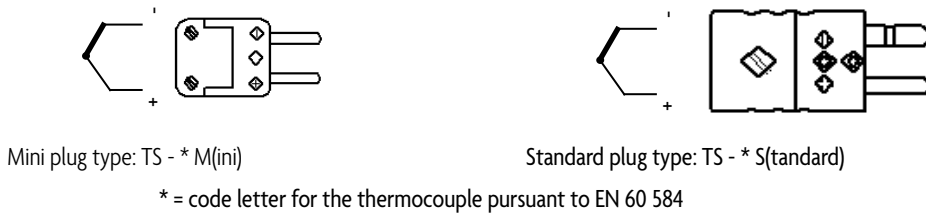

Measuring point design

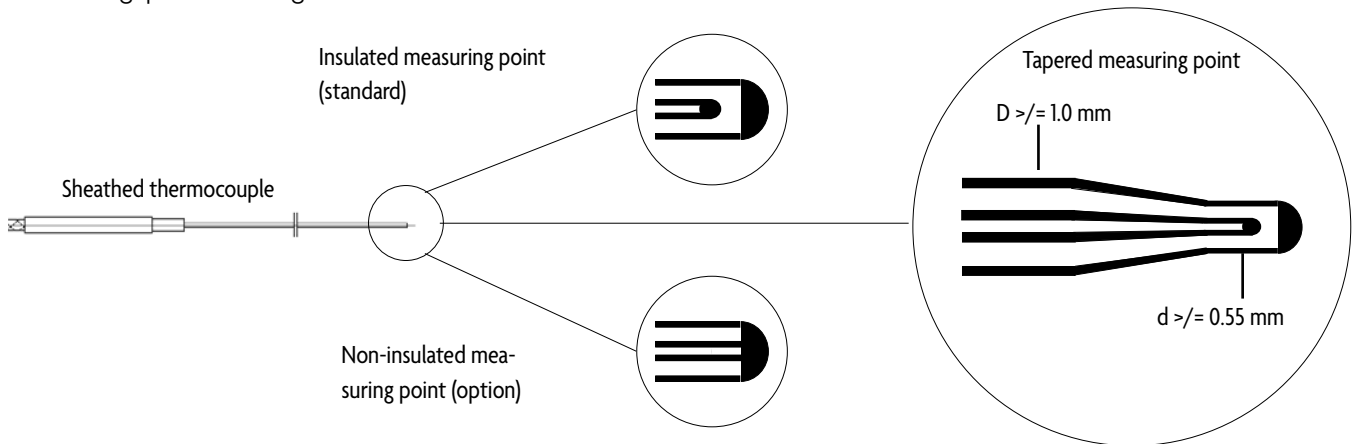

With dual thermocouples, the measuring points are galvanically isolated from each other and the sheath!

Head versions: Design B

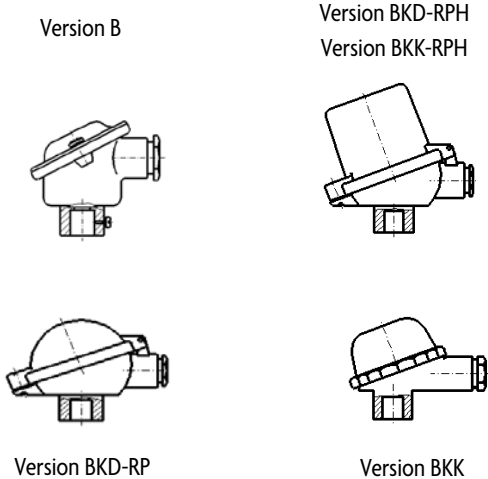

Connection heads:

This version includes a type B connection head made from die-cast aluminum in accordance with EN 50 446. Heads with raised covers, e.g. for installing one or two transducers are also available (types BKD-SPH or BKD-RPH).

A version made from plastic with a screw cover, type BKK and hinged cover, type BKK-RPH, is also available. The cable connection on all connection heads is M 20 x 1 (PG 16) as standard. The protection class for the heads is IP 43 as standard. Other protection classes (e.g. IP 54/65/66 ) and heads made from other materials are available on request.

ORDER CODE STRUCTURE

Version-thermocouple-material-diameter-length-cable length

Versions	<p>AL With connection cable</p> <p>ALS With cable and round coupler</p> <p>ALSTE With cable and thermocouple connector</p> <p>S With round coupler</p> <p>STE With thermocouple connector</p> <p>TMM Sheath measuring insert</p> <p>B-KB With connection head type B</p> <p>AL-RT With weld plate</p>	<p><b>Example:</b> <b>ALSTE</b> - <b>KB</b> - <b>3.0</b> - <b>600</b> - <b>3</b></p>	
Thermo-couples	<p>without number = 1 thermocouple</p> <p>2 = 2 thermocouples</p> <p>3 = 3 thermocouples</p>		
Thermocouple types pursuant to DIN EN 60 584	<p>E NiCr - CuNi</p> <p>J Fe - CuNi</p> <p>K NiCr - Ni</p> <p>T Cu - CuNi</p> <p>N NiCrSi - NiSi</p> <p>S Pt10%Rh - Pt</p> <p>R Pt13%Rh - Pt</p> <p>B Pt30%Rh - Pt6%Rh</p>	High temperature thermocouple types	
		<p>A W5%Re - W20%Re</p> <p>D (AO) W3%Re - W25%Re (ASTM 988)</p> <p>C (AE) W5%Re - W26%Re</p>	
Code letter for sheath material	<p>B Inconel 600, mat. no.: 2.4816</p> <p>D Heat resistant steel mat. no.: 1.4841</p> <p>E Stainless steel mat. no.: 1.4541</p> <p>AW Nimonic 75</p> <p>AA Platinum 6% rhodium</p> <p>AH Platinum 10% rhodium</p> <p>N Tantalum</p> <p>O Molybdenum</p>		
Sheath diameter	<p>0.15 dia. 0.15 mm</p> <p>0.25 dia. 0.25 mm</p> <p>0.35 dia. 0.35 mm</p> <p>0.5 dia. 0.5 mm</p> <p>0.75 dia. 0.75 mm</p> <p>1.0 dia. 1.0 mm</p> <p>1.5 dia. 1.5 mm</p> <p>1.6 dia. 1.6 mm</p>	<p>3.0 dia. 3.0 mm</p> <p>3.2 dia. 3.2 mm</p> <p>4.5 dia. 4.5 mm</p> <p>4.8 dia. 4.8 mm</p> <p>6.0 dia. 6.0 mm</p> <p>6.4 dia. 6.4 mm</p> <p>5.0/8.0 dia. 6.0 mm reinforced to 8.0</p> <p>8.0 dia. 8.0 mm</p>	
Thermocouple length in mm			
Cable length in m			



## HIGH TEMPERATURE THERMOCOUPLES

Sheath material	Type
Pt 6 % Rh - Pt	AA
Pt 10 % RH - Pt	AH
Tantalum	N
Molybdenum	O
Titanium	Q
Nickel	W
Niobium 1 % zirconium	AV
Molybdenum 50 % rhenium	BE
Incoloy	X

Wire material	Type
Pt 10 % Rh - Pt	
Pt 13 % RH - Pt	R
Pt 30 % RH - Pt 6 % RH	B
Ir 40 % Rh - Ir	V
W - W 26% Re	G (AA)
W3 % Re - W 25 % Re	D (AO)
W5 % Re - W 26 % Re	C (AE)
W5 % Re - W 20 % Re	A (AI)

Insulation material	Type
Magnesium oxide (MgO)	M
Aluminum oxide (Al <sub>2</sub> O <sub>3</sub> )	A
Hafnium oxide (HfO <sub>2</sub> )	H

We offer specially developed high temperature thermocouples for use in temperatures up to 2000 °C or for highly corrosive and/or reducing atmospheres. High temperature thermocouples are primarily used in the aerospace industry, crystal growing and research laboratories.

Suitable sheath materials, thermocouple combinations and insulating materials are available for various areas of application. Only precious metal types S, R and B as well as types A and C are internationally standardized in IEC 60584-1 and DIN EN 60584-1. Type V is described in ASTM E 1756.

New techniques were required to produce the measuring points due to the considerable load at high temperatures as a result of several factors. Only materials specially suited and tested for this purpose are used. The possible applications for the various materials depend largely on the environmental influences.

Use in air (oxidizing atmosphere) is only possible up to certain temperatures. This does not apply to platinum alloys. The sheath materials listed in the tables only constitute a selection of the available materials. Other materials are available on request.

Selecting a transition to a different material is advised for long platinum sheathed thermocouples for cost reasons. The installation length of the part exposed to the high temperatures can be customized and is referred to as a transition element.

### TRANSITION JOINT THERMOCOUPLE

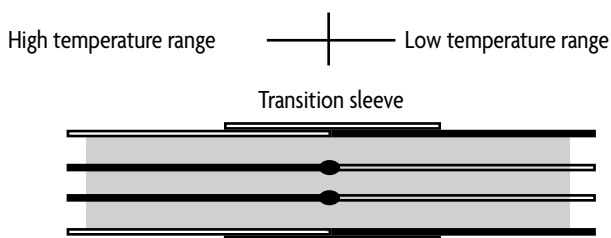

### Transition joint thermocouple

Standard transition joint

Sheath: AA, AH on inconel

Insulation: HfO<sub>2</sub>, on MgO or Al<sub>2</sub>O<sub>3</sub>

The following tests can be performed and certified on request:

- | Thermoelectric voltage test at different temperatures
- | X-ray images of the measuring point and transition piece
- | Helium leak test
- | Vibration test
- | Resistance tests
- | Sealing test (at free ends or at the transition to the compensating cable)
- | Material testing (sheath, thermocouple wires, insulation)

Recommendation for the use of high temperature thermocouples

Sheath material	Type	Thermowire type	Insulation	Permissible atmosphere	Max. short-term operating temperature
Pt 6 % Rh	AA	S, R, B & V	MgO	Oxidizing	1200 °C
Pt 10 % Rh	AH	S, R, B & V	MgO	Oxidizing	1200 °C
Pt 6 % Rh	AA	V, A, AA, C & D	MgO / HfO <sub>2</sub>	Oxidizing	1700 °C
Pt 10 % Rh	AH	V, A, AA, C & D	MgO / HfO <sub>2</sub>	Oxidizing	1300 °C
Tantalum	N	V, A, AA, C & D	MgO / HfO <sub>2</sub>	Inert/vacuum	1700 °C
Tantalum	N	A, AA, C & D	HfO <sub>2</sub>	Inert/vacuum	2150 °C
Molybdenum (Mo)	O	A, AA, C & D	HfO <sub>2</sub>	(Reducing)/inert/vacuum	(2200 °C) 2500 °C
Mo 50 % rhenium	BE	A, AA, C & D	HfO <sub>2</sub>	Reducing/inert/vacuum	2300 °C

Max. application temperatures and melting point of the pure materials

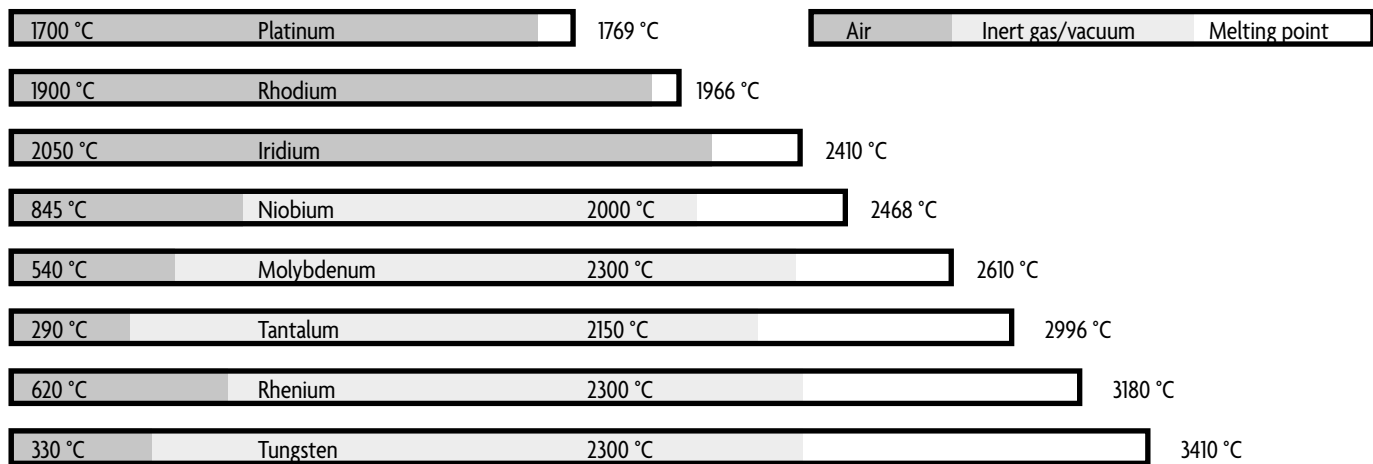

Thermoelectric voltages for high temperature thermocouples

Temperature in °C	W - W26%Re	W3%Re - W25%Re	W5%Re - W26%Re	W5%Re - W20%Re	Ir40%Rh - Ir
100	0.344	1.145	1.381	1.337	0.371
200	1.005	2.603	2.987	2.871	0.841
300	1.985	4.289	4.767	4.513	1.380
400	3.282	6.129	6.654	6.203	1.961
500	4.793	8.098	8.573	7.908	2.562
600	6.487	10.092	10.508	9.606	3.172
700	8.330	12.128	12.450	11.284	3.861
800	10.299	14.183	14.374	12.934	4.448
900	12.318	16.225	16.265	14.550	5.021
1000	14.392	18.242	18.120	16.127	5.576
1100	16.497	20.229	19.943	17.662	6.116
1200	18.647	22.191	21.724	19.150	6.643
1300	20.767	24.081	23.423	20.589	7.159
1400	22.813	25.896	25.032	21.976	7.669
1500	24.841	27.686	26.582	23.311	8.177
1600	26.849	29.450	28.078	24.593	8.687
1700	28.841	31.181	29.528	25.821	9.205
1800	30.813	32.874	30.922	26.997	9.732
1900	32.589	34.359	32.298	28.119	10.272
2000	34.245	35.723	33.632	29.186	10.826
2100	35.851	37.037	34.914	30.194	-
2200	37.435	38.306	36.088	31.142	-
2300	38.896	39.350	36.928	32.028	-
2400	-	-	-	32.855	-
2500	-	-	-	33.640	-

Thermoelectric voltages in mV, reference temperature 0 °C

## TECHNICAL INFORMATION:

**Sheathed thermocouple:**

Standard version: Thermocouples as per  
DIN EN 60 584-1  
Other versions available on request

**Limit deviation:**

Class 1 or 2 in accordance with DIN EN 60 584 - 1  
Confined limit deviations are available on request.

**Insulation resistance:**

Standard  $\geq 5000 \text{ MOhm} \cdot \text{m}$  at 23 °C  
Min. 1000  $\text{MOhm} \cdot \text{m}$  (DIN EN 61 515)

**Insulation material:**

High purity magnesium oxide (MgO)

**Sheath material:**

Inconel 600 mat. no.: 2.4816  
Heat resistant steel mat. no.: 1.4841  
Stainless steel mat. no.: 1.4541

**Sheath diameter (in mm):**

Standard series: 0.25; 0.5; 1.0; 1.5 ; 3.0 ; 6.0; 8.0  
Special series: 0.35; 1.6; 2.0; 3.2 ; 4.5 ; 4.8; 10.0

**Note:**

Dual versions are available from a sheath diameter of 1.5 mm (2 thermocouples in same sheath).

**Round couplers and connectors:**

LEMO round couplers size 0 or 1 are used for the S and ALS versions. Depending on the connection type, the couplers have 2 or 4 poles. The precision contacts are made of brass and are gold-plated. The brass outer casing is matt chrome-plated. Contacts made of thermocouple material in type K or type N are available on request. Other connector systems and sizes are also available on request. Matching mating connectors are available.

We reserve the right to make changes to account for technological advancement

**Cable types:****A) TT - 465 - 2K - 0.25 L (stranded):**

High quality thermocable class 1  
Insulated individually and jointly with FEP,  
Shielding braid Cu tin plated,  
2 x stranded wires 0.25 mm<sup>2</sup> cross-section,  
max. ambient temperature 220 °C

**B ) GG - 220 - 2K - 0.5 M (solid):**

High temperature thermocable class 1  
Insulated individually and jointly with  
special glass silk, 2 x solid wires dia. 0.5 mm,  
max. ambient temperature 400 °C

**C ) TP - 440 - 2KC - 0.25 L:**

Compensating cable  
Insulated individually with FEP and jointly with  
PVC, Cu shielding braid,  
2 x stranded wires 0.25 mm<sup>2</sup> cross-section,  
max. ambient temperature 85 °C

**D ) TG - 412 - 2KC - 0.25 L:**

Compensatory cable  
Single cable insulated with FEP,  
covered together with glass silk,  
braided with stainless steel wire,  
2 x stranded wires 0.25 mm<sup>2</sup> cross-section,  
max. ambient temperature 240 °C

**Thermocouple connectors and couplers:**

Thermocouple connectors and couplers are available in two sizes, i.e. mini and standard. Both designs contain the thermocouple material as contacts. The plug connector is designed to prevent polarity reversal. Connector systems are available for all thermocouple types as per DIN EN 60 584 and certain special types (W-Re thermocouples). The maximum ambient temperature is 150 °C. High temperature versions up to 285 °C and ceramic versions up to 425 °C are available on request.



**Hubert Topmüller**  
Furnace construction expert

**Henry Hall (M.A.)**  
Managing director

**Carsten Tillmann**  
Steel industry expert

**Frank Elsenbach**  
Automotive expert

**Jörg Reichelt**  
Managing director/semiconductor expert

## RÖSSEL-MESSTECHNIK – YOUR CERTIFIED PARTNER

As a leading manufacturer of temperature measuring technology for industrial and research purposes, we meet the strictest production standards. With internationally recognized approvals and calibrations, we offer quality you can rely on around the globe.





## GET TO KNOW US CONTACT





 **RÖSSEL Messtechnik GmbH**  
Seidnitzer Weg 9  
D-01237 Dresden



 +49 351 312 25-10

 [info@roessel-messtechnik.de](mailto:info@roessel-messtechnik.de)  
 [www.roessel-messtechnik.de](http://www.roessel-messtechnik.de)



 **RÖSSEL Messtechnik GmbH**  
Lohstraße 2  
D-59368 Werne

 +49 2389 409-0

 [info@roessel-messtechnik.de](mailto:info@roessel-messtechnik.de)  
 [www.roessel-messtechnik.de](http://www.roessel-messtechnik.de)